

HART IN-HEAD TEMPERATURE TRANSMITTER

SEM310

- > ACCEPTS PT100, T/C & SLIDEWIRE SENSORS
- > HART® PROTOCOL
- > UNIVERSAL INPUT
- > SENSOR BURNOUT DETECTION
- > ATEX VERSION AVAILABLE

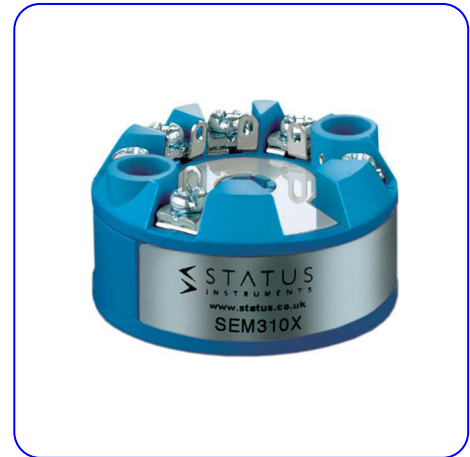

> INTRODUCTION

The SEM310 has the HART communications protocol which allows the user to quickly and easily download information or interrogate the device enabling the following:

- Simple re-ranging of sensor type and range.
- Easy on site re-calibration.
- Operation with proprietary software packages such as AMS Plant Web™ and Cornerstone™.
- Remote configuration on the (4 to 20) mA loop with a hand held communicator or with a PC & HART modem.
- Online Digital communication concurrent with a (4 to 20) mA Analogue signal.

The standard HART universal and common usage commands are implemented, with other device specific commands that enable access to the enhanced performance parameters of the SEM310.

> ENHANCED FEATURES

Some of the enhanced SEM310 features are as follows;

SENSOR REFERENCING

The SEM310 sensor referencing via the Windows based M-Config software allows for close matching to a known reference sensor eliminating possible sensor errors.

USER CALIBRATION

In addition to sensor referencing, user offset and current output trimming is possible via the HART commands.

CUSTOM LINEARISATION

The [X]*1 facility allows the SEM310 to be programmed with a custom linearisation to suit non standard sensors or sensors with unusual or unique characteristics. Consult the sales office for details.

SENSOR BURN OUT DETECTION

If any sensor wire is broken or becomes disconnected the SEM310 output will automatically go to its user defined level (upscale or downscale). This happens irrespectively of which wire is broken.

OUTPUT CURRENT PRESET

For ease of system calibration and commissioning the output can be set to a pre-defined level anywhere within the (4 to 20) mA range.

Hart® Registered trademark of the HART Communication Foundation.

> SPECIFICATIONS @20 °C

Input Types	Pt100, Thermocouple, mV or Slidewire. (Ni100, via Custom[X]*1 facility)
Time Constant (Filter off)	0.5 s (to 90 % of final value) Filter Factor Off/selectable between 1 s and 32 s or Adaptive
Warm-up Time	120 s to full accuracy
Input/Output Breakdown Isolation	500 VAC
ENVIRONMENTAL	
Operating Range	(-40 to 85) °C
Storage Temperature	(-50 to 85) °C
Humidity Range	(0 to 95) % (non condensing)
APPROVALS	
EMC	BS EN61326
Hazardous Area	ATEX FM II1GEEExia IICT4-T6 FM3610-IS/1/1/ABCD/T4

HART IN-HEAD TEMPERATURE TRANSMITTER

OUTPUT

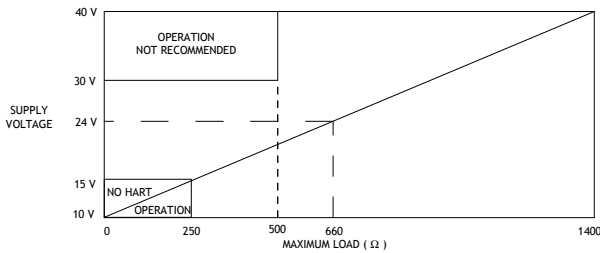

Maximum Output Load $[(V_{\text{supply}}-10)/21.5]$ K Ω , 250 Ω minimum loop load. Supply voltages over 30 V a minimum loop load of 500 Ω is necessary.

Burnout Levels Low 3.75 mA, High 21.5 mA
 Input Out of Range Low 3.8 mA, High 20.5 mA
 Output Range (4 to 20) mA, Min. 3.75 mA, Maximum 21.5 mA
 Accuracy $\pm 5 \mu\text{A}$
 Thermal Drift $1 \mu\text{A}/^\circ\text{C}$
 Supply Voltage (10 to 40) VDC
 Supply Voltage Effect $0.2 \mu\text{A}/\text{V}$

Hart TrimDac function available.

ENCLOSURE

Material ABS
 Flammability SEI UL94-V0

MECHANICAL

Weight 43 g

INPUT SENSORS & RANGES

Pt100 (RTD) 2, 3 or 4 Wire

Sensor Range (-200 to -850) $^\circ\text{C}$
 (18 to 390) Ω
 Minimum Span 25 $^\circ\text{C}$
 Linearisation BS EN 60751, BS 1904, DIN 43760, JIS1604, CUSTOM [X]*¹
 Max Lead Resistance 50 Ω per leg
 (balanced for 3 wire)
 Basic Measurement Accuracy*² $0.01\% \text{ FRI}^*3 \pm 0.07\% \text{ rdg}$

RTD Excitation Current (300 to 500) μA
 Thermal Drift Zero $0.008 \text{ }^\circ\text{C}/^\circ\text{C}$
 Span $0.01\%/^\circ\text{C}$

THERMOCOUPLE

Type	Range $^\circ\text{C}$	Minimum Span $^\circ\text{C}$
TC Type K	-200 to 1370	50
TC Type J	-200 to 1200	50
TC Type T	-210 to 400	25
TC Type R	-10 to 1760	100
TC Type S	-10 to 1760	100
TC Type E	-200 to 1000	50
TC Type L	-100 to 600	25
TC Type N	-180 to 1300	50
TC Type [X] ³	User defined	

Linearisation BS EN 60584-01, BS 4937, IEC 584-1

Basic Measurement Accuracy*² $0.04\% \text{ FRI}^*3 \pm 0.04\% \text{ rdg}$ or $0.5 \text{ }^\circ\text{C}$ (whichever is greater)

Cold Junction $\pm 0.5 \text{ }^\circ\text{C}$ tracking $0.05 \text{ }^\circ\text{C}/^\circ\text{C}$
 range (-40 to 85) $^\circ\text{C}$
 Thermal Drift Span $0.01\%/^\circ\text{C}$

MILLIVOLTS

Input Voltage source
 Range (-10 to 75) mV
 Characterisation Linear, Custom [X]*¹
 Minimum Span 5 mV
 Basic Measurement Accuracy*² $\pm 10 \mu\text{V} \pm 0.07\% \text{ rdg}$
 Input Impedance 10 M Ω
 Thermal Drift Zero $0.1 \mu\text{V}/^\circ\text{C}$
 Span $0.01\%/^\circ\text{C}$

SLIDEWIRE

Input 3 wire potentiometer
 Resistance Range (10 to 390) Ω end to end
 (Larger values can be accommodated with an external resistor)
 Range (0 to 100) %
 Characterisation Linear, Custom [X]*¹
 Minimum Span 5 % of FRI*³
 Thermal Drift Zero $0.005\% \text{ of Span } /^\circ\text{C}$
 Span $0.01\%/^\circ\text{C}$
 Basic Measurement Accuracy*² $0.1\% \text{ of FRI}^*3$

*Notes:

- 1) Customer linearisation is available pre-programmed at the factory, contact sales office for details.
- 2) Basic Measurement Accuracy includes the effects of calibration, linearisation and repeatability.
- 3) FRI = Full Range Input

M-CONFIG SOFTWARE

COMMUNICATING WITH THE SEM310 HART TRANSMITTERS

The SEM310 can communicate digitally, concurrent with the analogue (4 to 20) mA output signal. This can be achieved in a number of ways namely:

- Proprietary hand held communicator.
- PLC's, DCS's etc with HART interface.
- PC Computers using M-Config (available download free from www.status.co.uk) and a HART modem.

COMMUNICATING WITH A HAND HELD COMMUNICATOR

The SEM310 will communicate with any proprietary HART communicator and access to all universal commands is available from the communicator. In order to access all the parameters available, the communicator must have the correct HART Device Description (DD) installed.

COMMUNICATING WITH PLC'S OR DCS'S

Any system that supports HART field devices using such software packages as AMS-Plant Web™ or Cornerstone™ will communicate with the SEM310 enabling access to advanced system features such as self documentation and diagnostics. The correct DD must be installed for full access to all parameters.

HART IN-HEAD TEMPERATURE TRANSMITTER

COMMUNICATION WITH A PC

Communication with a PC is easily accomplished by using the HART modem supplied with the communications kit, and M-Config software. M-Config is the menu-driven software product from Status Instruments which runs under Windows and enables the following functions to be quickly and easily performed:

- Change sensor type, range, select burnout direction, filter(damping), factor.
- Set tag numbers, assembly numbers, calibration details, messages etc
- Print or save to file all relevant documentary information.
- Read next calibration date.
- Perform basic calibration (TrimDac, user offset).
- Monitor sensor status and read transmitter diagnostics.
- Real-time reading of process variable.
- Supports up to 15 devices in multi-drop mode.

M-Config software is very 'User-friendly' and can be used immediately without extensive training. The user is guided through a series of simple menu screens where the information is clearly and logically represented. It is available as a free download on www.status.co.uk

MULTIDROP HART

As well as operating in standard mode the SEM310 supports HART Multidrop mode whereby up to 15 devices can be connected to the same pair of wires enabling full digital functionality with each device.

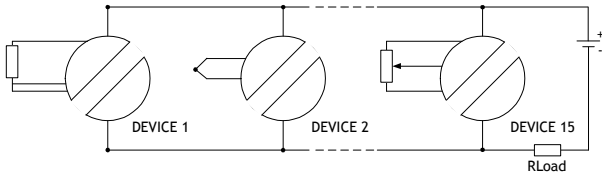

*In multi-drop mode the current output is set at 4 mA.

MECHANICAL DETAILS

(All dimensions in mm)

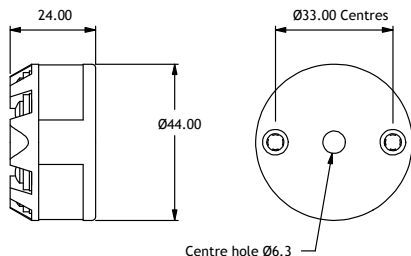

CONNECTIONS

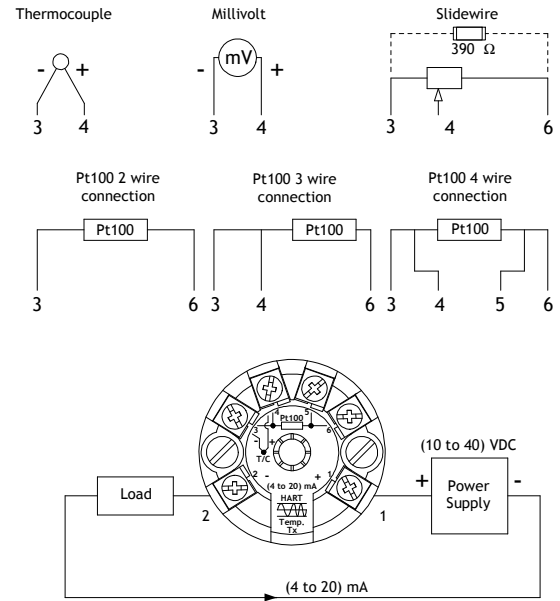

HAZARDOUS AREA

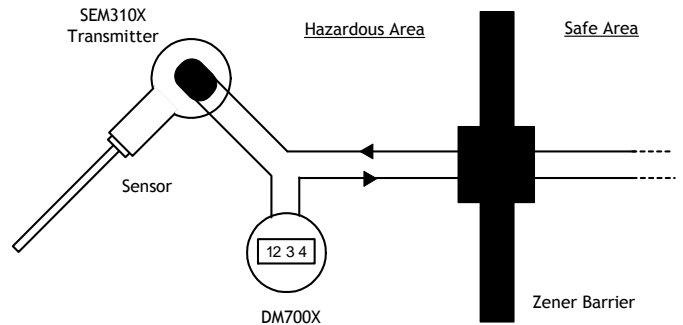

Order Code:

SEM310
SEM310X

Hart Transmitter
Hart Transmitter IS Version

M-CONFIG

Software for the RCP2 Comms Kit available free from www.status.co.uk

RCP2-KIT-UK
RCP2-KIT-EUR
RCP2-KIT-USA
RCP2-KIT-AUS

* Kit for UK use
* Kit for European use
* Kit for use in USA / Canada
* Kit for use in Australia

* Kit comprising: M-CONFIG, PSU, CONFIG-03, HART modem