HT2012

HART Modem FSK 1200 bps.



Description

The HT2012 is a CMOS modem designed for HART field instruments and associated interfaces. This component require some external active and passive elements to provide the functions needed to satisfy HART physical layer requirements including modulation, demodulation, receive filtering, carrier detect, and transmit signal shaping.

The HT2012 is ideal for low power field instruments (4 to 20mA) and can be used also for computer interfaces for data acquisition and control. It uses phase continuous frequency shift keying (FSK) at 1200 bits per second as specified in HART protocol. It work in half duplex mode in order to save power.

Features

- Ideal for HART field instruments, configurators, data acquisition and digital control.
 - Bell 202 FSK at 1200 and 2200 Hz, nominal 1200 bits per second, half duplex.
 - CMOS technology, working from 3.0 to 5.5V Power Supply, extra low current 40uA.
 - Transmit wave shaping, receiver band pass filter, with few external components.
 - Work with most micro controllers available in the market, I/O CMOS/TTL compatible.
 - Industrial temperature -40 to 85C, Pb-Free chip packaging.
 - Based on HART physical layer.
-

The purpose of this document is assist with the setup, installation, operation and maintenance of the HT2012 as well as providing technical specifications and basic data, for further information about this product can be found at www.springres.com

Table of Contents

1 - General information	02
2 - Functional Description	04
3 - Modem Characteristics	05
4 - Electrical Characteristics	08
5 - General Notes	09
6 - Mechanical Specification	12

1 General Information

The HT2012 HART® (Highway Addressable Remote Transducer) is a single chip CMOS low power FSK modem which operates at the Bell 202 standard. It is designed to provide HART® communication capabilities in process control instrumentation and other low power equipment, and provides a low cost, reliable single chip modem capability conforming to the HART® Physical Layer.

The HT2012 is ideal for factory automation, process control, and other applications that require low power such as intrinsically safe environments. The modem circuitry is digital, and includes both modulating and demodulating functions. The HT2012 is designed for use with external circuits that amplify, filter, and shape the media signals, operates from a single 3.3 to 5.0 Volts power supply, and requires an externally generated clock of 460.8 kHz.

The HT2012's operation is half duplex, with the modulator and demodulator controlled by the INRTS pin. It operates at the Bell 202 standard upper (forward) bit rate of 1200 bits per second, and uses Bell 202 standard nominal shift frequencies of 1200 Hz and 2200 Hz. An active low carrier detect output and 19.2 kHz clock output are provided in a 28 pin Plastic Leaded Chip Carrier (PLCC) package (See Figure 1). With proper media conditioning, the HT2012 can communicate with other commercial Bell 202 modem without either external adjustments or special biasing.

Table 1. PIN DESCRIPTION

Signal	Type	PLCC Pin	Description
VDD	–	1	+3.3 to 5.0 Vdc power supply
019_2k	Output	2	User Clock (16x bit rate. Nominally 19.2 kHz)
OCD	Output	3	Carrier Detect (Low (0) when carrier present)
IRXA	Input	4	Demodulator Input (accepts 1200 or 2200 Hz square wave modulated carrier)
NC	–	5-12	No internal connection
Input TEST1	Input	13	Test Input One (Must be connected to VSS during normal operation)
ORXD	Output	14	Demodulator Output. Provides a logical 1 in response to a 1200 Hz FSK square wave signal at IRXA; a logical 0 to 2200 Hz. Demodulation only takes place when INRTS is high (1). ORXD output is undefined when INRTS is low (0)
VSS	–	15	Power Supply Ground
OTXA	Output	16	Modulated Output. Provides a 1200 Hz square wave FSK output in response to a logical (1); 2200 Hz in response to a logical (0). Active when INRTS is low (0). Goes to high impedance state when INRTS is high (1)
$\overline{\text{INRTS}}$	Input	17	Request To Send. Selects operation of modulator when low (0); demodulator when high (1). Causes OTXA to go to high impedance state when high (1)
NC	–	18-25	No internal connection
Input TEST0	Input	26	Test Input Zero. Must be connected to VSS during normal operation
ITXD	Input	27	Modulator Input. Accepts input data (logical 0 or 1) for carrier output modulation at OTXA
I460k	Input	28	Input Clock. Clocks modem circuits. Frequency is nominally 460.8 kHz

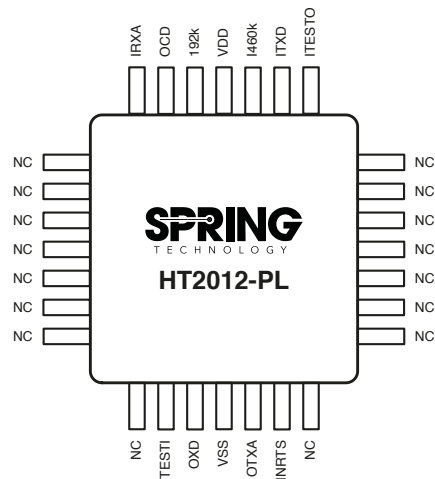

Figure 1 - Pin Out Packages

2 Functional Description

The HT2012 has four major function blocks: carrier detect, clock/ timing, modulation, and demodulation. The nominal bit rate is 1200 bits per second. The HT2012 uses shift frequencies of nominally 1200 Hz (mark = binary 1) and 2200 Hz (space = binary 0).

Clocks

A digital input frequency of 460.8 kHz is accepted from an external source, and is used to generate several internal clocks. All circuit operations can be performed with a master clock frequency of 460.8 kHz. This frequency is significantly lower than clock frequencies used by other single chip modems and results far lower power requirements. Power consumption is further reduced by various sections of the modem being shut down (not clocked) when not in use.

One internal clock at a nominal frequency of 19.2 kHz is brought to an output pin, enabling reconstruction of the data in external circuits.

Demodulator

The demodulator accepts an FSK signal at its IRXA input and reproduces the original modulating signal at the ORXD output. Both input and output signals are digital.

Modulator

Digital data in NRZ form is accepted at the ITXD input. An FSK modulated signal is generated at the OTXA output. The modulator provides phase continuous modulation. The phase angle of the modulated signal is preserved when switching between shift frequencies.

Carrier Detect

The nominal bit rate is 1200 bits per second. The HT2012 uses shift frequencies of nominally 1200Hz (mark) and 2200 Hz (space).

If the measured interval time falls outside these limits for a period of time after the carrier has been detected carrier detect output is not asserted.

3 Modem Characteristics

The HT2012 incorporates a Bell 202 compatible 1200 baud modem which implements Frequency Shift Keying (FSK) techniques used to transfer data. A 1200 Hz tone represents a mark while a 2200 Hz tone represents a space. The half duplex operation permits data rates up to 1200 bits per second in both transmit and receive modulation modes.

The HT2012 HART® modem has four main subsections: carrier detect, clock/timing, modulation, and demodulation.

Carrier Detect

The carrier detect output is active low whenever a valid carrier tone between 1000 and 2575 Hz (inclusive) is detected. Detection occurs when timed transitions remain within the band of the 1200 and 2200 Hz periods for 40 nanoseconds to 1 Bit time. A loss of carrier for 1 millisecond or more causes the carrier detect line to go inactive high (1).

Carrier Detect Frequency Range:

1000 Hz to 2575 Hz

The range of frequencies applied at IRXA over which OCD must go low (0).

Time from Carrier Input to Carrier Detect:

40 nanoseconds (Minimum) 1 bit time (Maximum)

The time from the start of a valid carrier signal at IRXA until OCD goes to logical low (0).

Time From Carrier Loss to Carrier Undetect:

1.68 milliseconds (Maximum)

The time from the lose of a valid carrier signal at IRXA until OCD goes to a logical high (1).

Conditions:

1. Clock frequency of 460.8 kHz +/- 0.1%
2. Input (IRXA) asymmetry maximum of 5.0%

Clocking and Timing:

The HT2012 requires a 460.8 kHz clock to generate all internal and external timing and control signals. Internal clocks are turned off when a section is not being used to minimize power requirements. The 460.8 kHz input frequency further reduces power requirements compared to most other modem chips that require higher input clock frequencies.

A 19.2 kHz signal is brought outside the HT2012 to support reconstructing data external to the chip. This is the same signal used internally to synchronize operations and is useful for designers who want to preserve that synchronization externally.

The 460.8 kHz clock is divided to generate 1200 and 2200 Hz mark and space frequencies. Dividing by 3 generates 153.6 kHz and dividing by 5.5 generates 83.8 kHz. A common divide by 70 then yields 2194.3 and 1196.9 Hz respectively, resulting in a small phase error of 9.5 degrees and 5.2 degrees (See Figure 2).

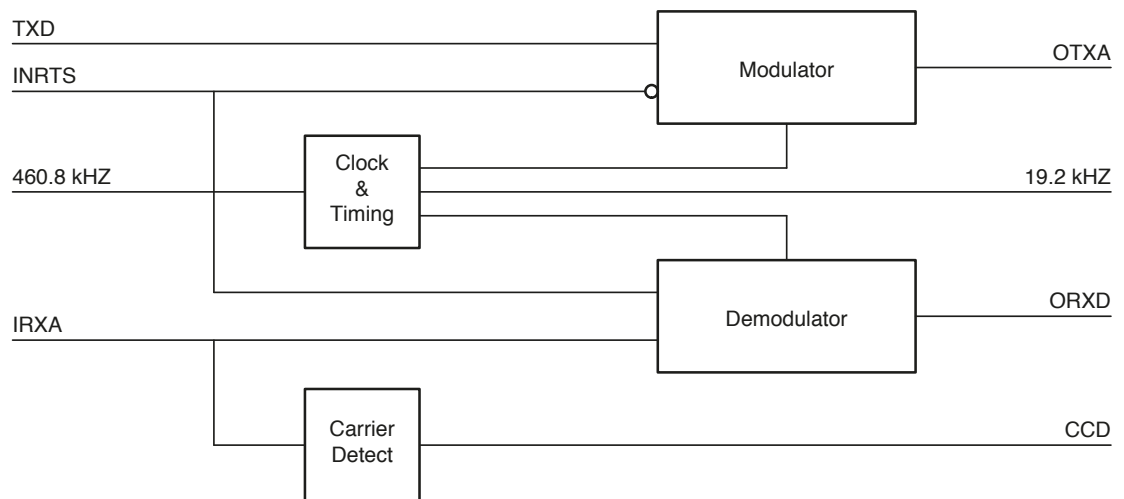

Figure 2. Modem Characteristics

User Clock Frequency:

Nominal 19.2 kHz
Proportional to the 460.8 kHz clock at I460K

Modulator

The modulator takes data to transmit and modulates it as either 1200 Hz (mark) a 2200 Hz (space). The input signal to transmit is applied to the ITXD pin as an NRZ digital signal. The output on the OTXA pin is the FSK modulated signal and is ready to be connected by the line driver and cable interface circuitry.

An important feature of the modulator is its preservation of the phase integrity of each frequency when switching between frequencies. This enables accurate reconstruction of the original modulating signal at the output of the demodulator (See Figure 4).

The clock/timing section generates timing and reference frequencies for the modulator. Output transitions are examined as to when they occur, limiting the maximum accumulated timing error to 12 microseconds, the period of the slower modulation frequency.

Modulator Output Frequency (at OTXA pin):

2194.3 Hz - Nominal High
Frequency (space).
1196.9 Hz - Nominal Low
Frequency (mark).

Modulator output frequencies are proportional to the input clock frequency.
Modulator Phase Continuity Error: Maximum +/- 10 degrees

Demodulator

The input signal from the IRXA pin is a digital pulse train consisting of the FSK modulated square waves. The demodulated data stream is buffered at the ORXD pin as a digital output signal (See Figure 3).

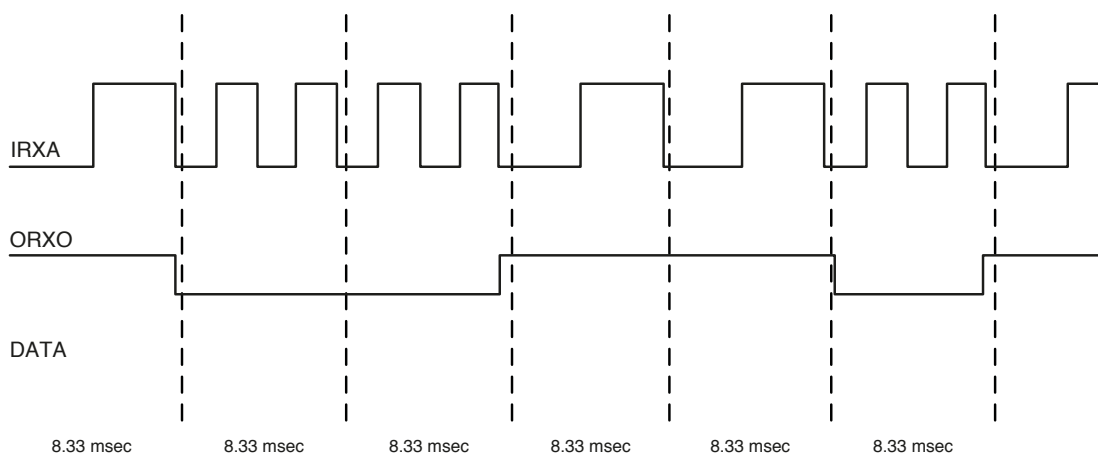

Figure 3. Typical Demodulator Signal

Maximum Demodulator Jitter:

+/- 12% of one bit time

Conditions:

1. Input frequencies at 1200 Hz +/- 10 Hz; 2200 Hz +/- 20 Hz
2. Clock frequency of 460.8 kHz +/- 0.1%
3. Input (IRXA) asymmetry = 0

4 Electrical Characteristics

Table 2. Electrical Characteristics

Parameter	Symbol	Min.	Max.	Unit
Storage temperature	TSTG	-65	+150	0°
Operating free-air temperature	TA	-40	+85	0°
Supply voltage (non-operating)	VDD		7	V

Table 3. AC Characteristics

Clock frequency	480.8 kHz +/- 0.1%
Clock pulse widths	150 nanoseconds min. (high and low levels)
Clock rise and fall time	10 nanoseconds (max.)
IRXA input rise and fall time	200 nanoseconds (max.)
Other inputs rise and fall time	50 nanoseconds (max.)
Output rise and fall time	10 nanoseconds (max.)

Notes:

- 1 All conditions apply over the full operating temperature range with 5.0 volt supply voltage.
- 2 Power should be disconnected before inserting or removing device.
- 3 Store device in conductive foam with all pins shunted to avoid damage from electrostatic discharge.
- 4 Avoid application of voltage or stresses over the maximum ratings.

Table 4. Operating Conditions

Symbol	Parameter	Min.	Max.	Unit	Condition
VDD	Supply voltage	3.0	5.5	V	
VIN	Input voltage	VSS - 0.3	VDD +0.3	V	
VIH	Logical 1 input voltage	2.0	VDD +0.3	V	
VIL	Logical 0 input voltage	VSS - 0.3	0.8	V	
VOL	Output low voltage		0.4	V	Output sink current (4.0mA)
VCH	Output high voltage	2.4	VDD - 0.3	V	Output source current (4.0mA)
IDD*	Supply current during demodulation (typical)	40		μA	@ 5.0v
IDD*	Supply current during modulation (typical)	80		μA	@ 5.0v
IIN	Input leakage current		+/- 1	μA	typical
ITO	High impedance output leakage current		+/- 10	μA	typical
ICIN	Input capacitance		10	pF	typical

* 50pF load to all outputs; all input rise and fall times satisfied; clock frequency = 460.8 kHz +/- 0.1%

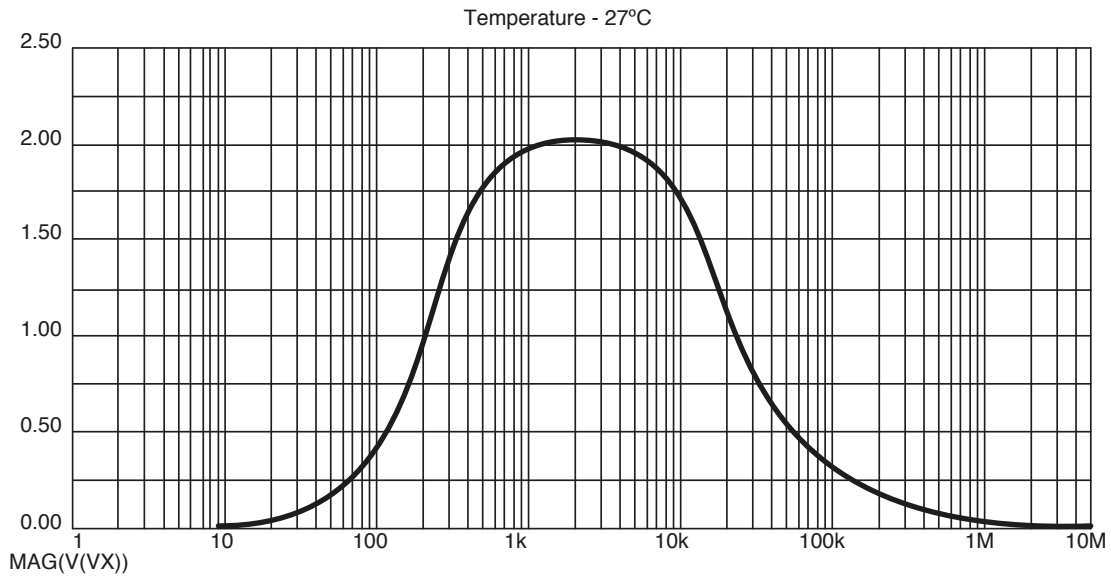

Figure 4. Gain Vs. Frequency Curve

5 General Notes

The HT2012 is designed for use as a peripheral device to a local microprocessor or microcontroller. All interface lines are digital and can directly connect to CMOS or TTL level components. The HT2012 requires two interfaces; one to the local microprocessor or microcontroller, and a second to the medium (See Figure 5).

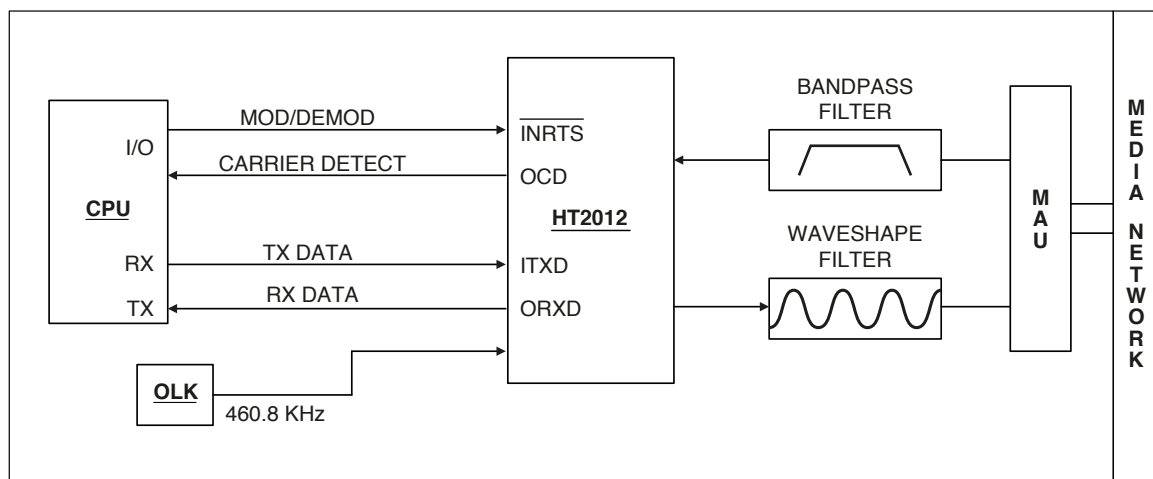

Figure 5. Typical Hardware Design

Microprocessor Interfacing

In its simplest form, the HT2012 is either in the transmit mode or the receive mode depending on the state of the INRTS control signal from the local microprocessor.

If $\overline{\text{INRTS}}$ is logic 0, the modulator is enabled and transmit data is modulated and output on the OXTA pin. The demodulator section is turned off to save power.

If $\overline{\text{INRTS}}$ is logic 1, the demodulator is enabled and the demodulated data from the IRXA pin is output to the ORXD pin. The modulator is turned off to save power.

When the demodulator is active, the carrier detect line (OCD pin) is active low when a valid carrier is present, and inputting demodulated data can begin.

Note:

When the HT2012 is in transmit mode ($\overline{\text{INRTS}} = 0$) the OCD carrier detect pin is active low because it is still sensing the activity of the carrier being transmitted. In this case, even though the carrier detect is active low, no modulated data is available from the ORXD pin.

Medium Interfacing

A typical application will send transmitted data over a signal medium and receive data over the same medium in a half duplex mode. The signal medium interface will vary and in most cases will contain an input bandpass filter as well as an output wave shaping filter (See Figure 6).

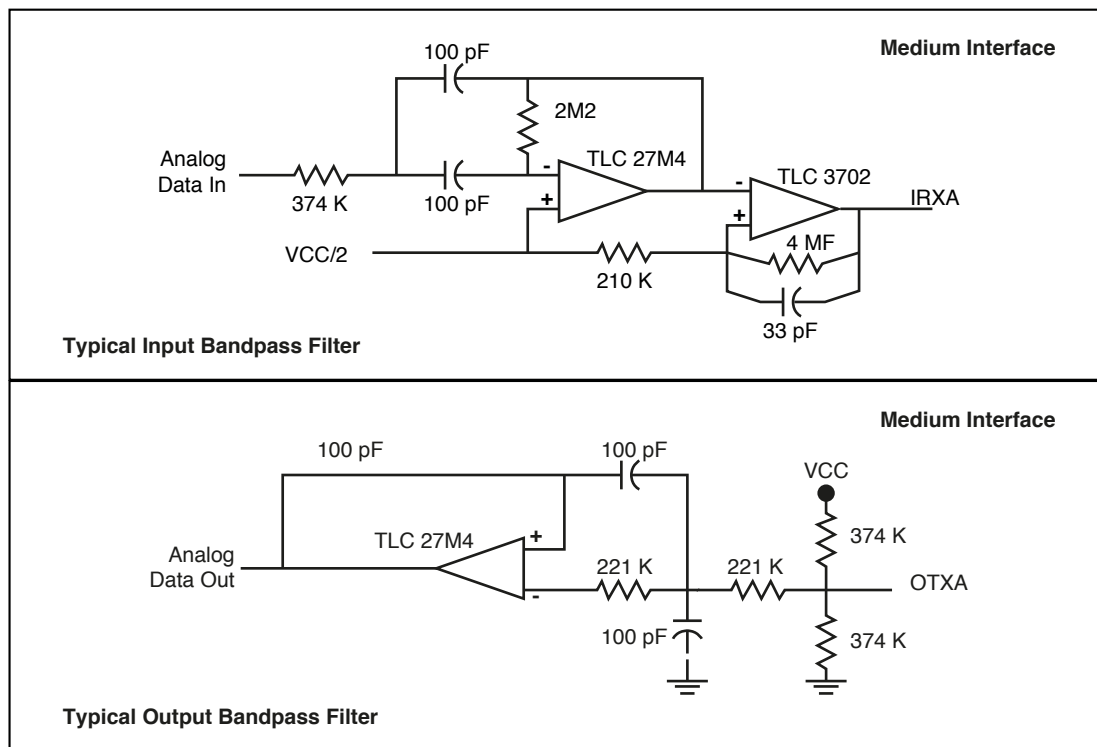

Figure 5. Typical Bandpass Filter and Output Wave Shape Filters

The input filter consists of a bandpass filter and a square wave shaper to regenerate the digital square waves to the HT2012. The square wave shaper is a comparator which functions as a zero cross detector. The comparator has a threshold set at half signal level, squaring the input signals and regenerating the sharp edges required by digital circuits. The timing characteristics of the originally transmitted signal are preserved for the accurate decoding of Manchester data.

The bandpass filter is used to reduce induced noise on the received signal, and is needed to smooth sharp transitions and eliminate high frequency components of the input signal. The pass band starts at around 1200 Hz and cuts off at around 2200 Hz. Depending on the signal medium and transmit signal levels, front end gain might be required before applying the signal to the bandpass filter.

The output wave shaping filter functions as a current to voltage modulator and smooths transition edges to minimize spurious frequencies and harmonics over the transmission lines. This helps eliminate false triggers at the remote receiver due to noise centered on the transition threshold. A simple integrator can be used, depending on the medium interface. In some applications an output filter is not required if the transmission medium can accept square waves directly without inducing or radiating unacceptable levels of noise.

An important characteristic of both filter designs is that they exhibit relatively constant phase delays over the operating bandwidth. This helps assure accurate timing characteristics for the regenerated demodulated signal (See Figure 7).

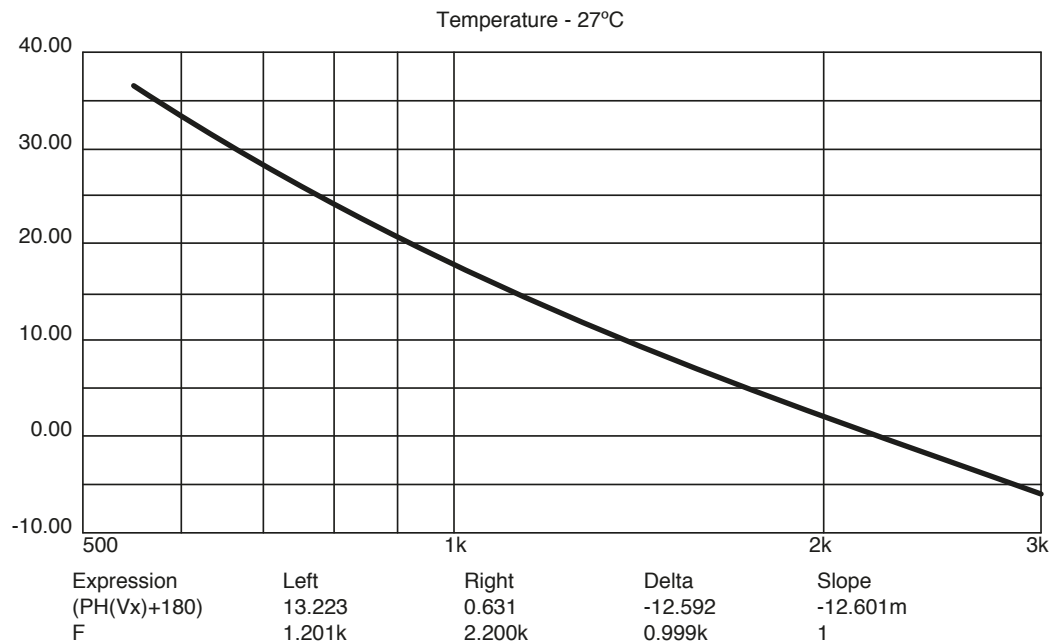

Figure 7. Phase Shift Vs. Frequency Curve

6 Mechanical Specification

Symbol	Min.	Nom.	Max.
A	.165	.172	.180
A1	.099	.101	.110
D	.485	.490	.495
D1	.450	.452	.455
D2	.390	.420	.430
D3	.300 REF		
E	.485	.490	.495
E1	.450	.452	.455
E2	.390	.420	.430
E3	.300 REF		
e	.050 BSC		

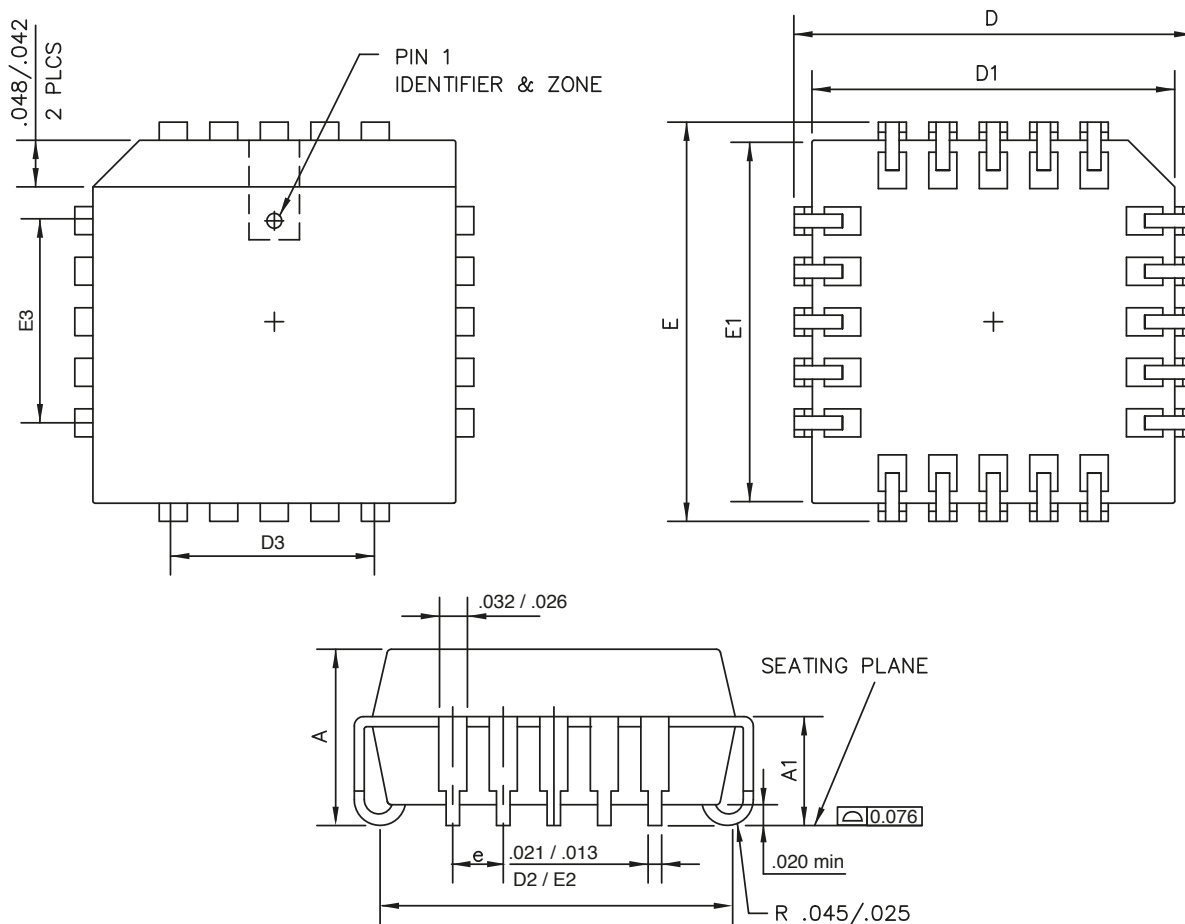
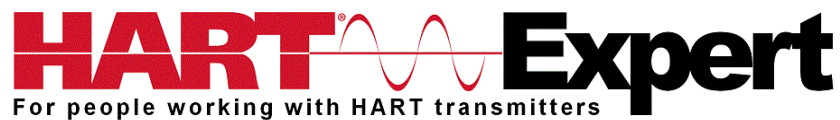

Figure 11. 28-pin PLCC Mechanical Specification

Supplied by:



HART Expert Ltd
31 Kingfisher Way,
Romsey,
Hampshire,
SO51 7RY, UK
Phone: +44 (0)7966 233639
Email: info@hart-expert.co.uk
Web: www.hart-expert.co.uk

Produced by :

Springfield Research reserves the right to make changes to design and functionality of any product without notice. Springfield Research does not assume any liability arising out of the application or use of any product. Springfield Research logo is registered trademarks of Springfield Research. HART is a registered trademark of the HART Communication Foundation. © 2015 Springfield Research Corp. All rights reserved



Springfield Research Corporation
3350 NW 22nd Terrace Suite 500 • Pompano Beach, FL USA 33069
Tel: +1 (954) 657.8849 • Fax: +1 (954) 657.8895 • sales@springres.com • www.springres.com

